

# Michigan Weight & Axle Load Limits

A simple guide for maximum axle load limits.

Not intended for legal purposes.

# Michigan Weight and Axle Load Limits

Understanding the axle and weight load limits can be very confusing. To better help you understand, the following is a simple guide for maximum axle load limits that is not intended for legal purposes. You are responsible for familiarity with the complete weight laws found in the Michigan Vehicle Code, Section 257.722. Should you have questions about weight limits, please call our hotline at (800) 682-4682.

## General Information

Maximum load limits may depend on the following:

- What type of highway you are operating on (See page 28 for highway types)
- The number of axles and the distance (spacing) between the axles or axle assemblies on which the vehicle or combination of vehicles is operated (**spacing is the distance between axles, measured from the center of one axle to the center of another axle**)
- The gross vehicle weight of the vehicle or combination of vehicles
- Tire width (published by the manufacturer)

Depending on the conditions above, your vehicle may be subject to the maximums found under the bridge formula or the normal loading standards.

## Federal bridge gross weight formula general information

The bridge formula applies to vehicles operating on interstate highways and specially designated highways which:

- Do not exceed 80,000 pounds gross weight
- Do not exceed the maximum allowed under the formula

**NOTE 1:** A vehicle exceeding 80,000 pounds gross vehicle weight or exceeding the maximum allowed under the formula is subject to normal loading standards

**NOTE 2:** Except five-axle, truck-tractor semitrailers having two consecutive sets of tandem combinations

The bridge formula allows for:

- 20,000 pounds for an axle with at least 9 feet of spacing on each side
- 34,000 pounds for a tandem-axle assembly (allowed when two consecutive sets of tandem axles have axle spacing of 36 feet, measured for the first and last axles of the consecutive sets; see definition on page 10)
- Weights for groups determined by using the bridge gross weight formula (see chart on inside back cover)

## Normal loading maximum general information

*MVC 257.722*

Maximum loads shall not exceed the number of pounds in the following provisions:

- 18,000 pounds on an axle with at least 9 feet of spacing from any other axle  
**NOTE:** Weight cannot exceed 700 pounds per inch of the width of the tire (“width” means as published by the manufacturer)
- 13,000 pounds per axle when axle spacing is less than 9 feet between two axles but more than 3.5 feet
- Axles less than 3.5 feet apart shall not exceed 9,000 lbs. per axle

**It is your responsibility to be aware of frost law restrictions along with county and city weight limits.**

**State Frost Law Information  
(800) 648-8960**

# Michigan Weight and Axle Load Limits

## Frost law restrictions

When spring weight restrictions are in effect on frost-restricted routes, axle loadings are reduced by 25 percent on rigid-based roads and 35 percent on flexible-based roads. **Most restricted state highways and county roads reduce axle loading by 35 percent.** Speed limits on frost restricted routes are reduced to 35 mph for every vehicle over 10,000 lbs. gross weight.

**For state frost law information, call (800) 787-8960.**

## County and city weight limits

Allowable axle weights on local roadways must be consistent with state law, but final weight determinations are the responsibility of the local jurisdictions. The limitation of 700 lbs. per inch of tire width still applies. **“Access” to/from state or federal highways on local roadways cannot be assumed.** Local jurisdictions also apply width and length limitations to their roadways and retain the authority to issue or deny special permits. **You should contact the appropriate jurisdiction for specific information prior to movements upon local roadways.**

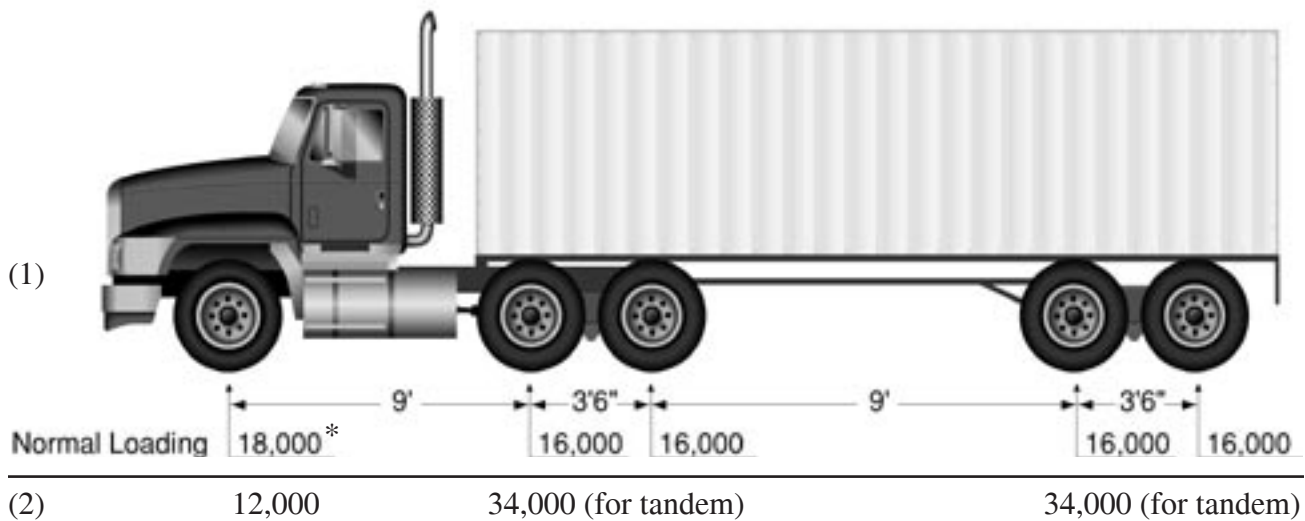

**Example (1)** On a combination of truck tractor and semitrailer having not more than 5 axles, 2 consecutive tandem axle assemblies shall be permitted on the designated highways at a gross permissible weight of 16,000 pounds per axle, if there is no other axle within 9 feet of any axle of the assembly.

*\*Steering axle weights can be a maximum of 18,000 lbs. (11,700 frost restriction) if equipped with high pressure pneumatic or balloon tires.*

**Example (2)** is federal law for interstate highways when the gross vehicle weight is 80,000 pounds or less and the distance between the center of the two tandem assemblies is 36 feet or more. State and local authorities may allow these weights on highways or sections of highways under their jurisdictions.

**NOTE:** Weight cannot exceed 700 pounds per inch of the width of the tire (width as published by the manufacturer). **Weight cannot exceed the tire load limit rating that is marked on the sidewall of the tire.**

**As previously stated, you should contact the appropriate jurisdiction for specific information prior to movement upon local roadways.**

# Michigan Weight and Axle Load Limits

Examples of normal load maximums; frost law restrictions shown are at the 35 percent reduction.

Weights based on 11:00 tires.

Steering axle weights can be a maximum of 18,000 lbs. (11,700 frost restriction) if equipped with high pressure pneumatic or balloon tires.

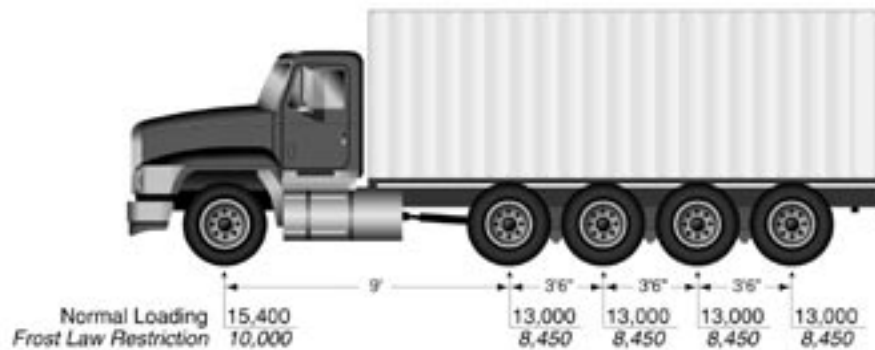
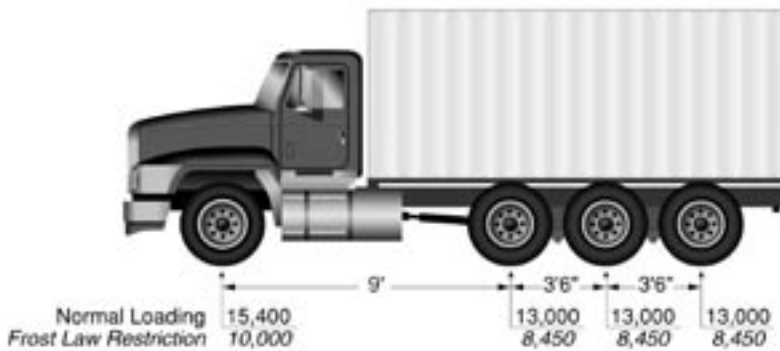
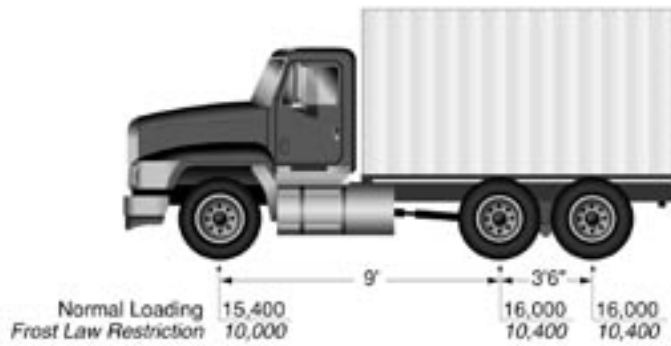

# Michigan Weight and Axle Load Limits

Examples of normal load maximums; frost law restrictions shown are at the 35 percent reduction.

Weights based on 11:00 tires.

Steering axle weights can be a maximum of 18,000 lbs. (11,700 frost restriction) if equipped with high pressure pneumatic or balloon tires.

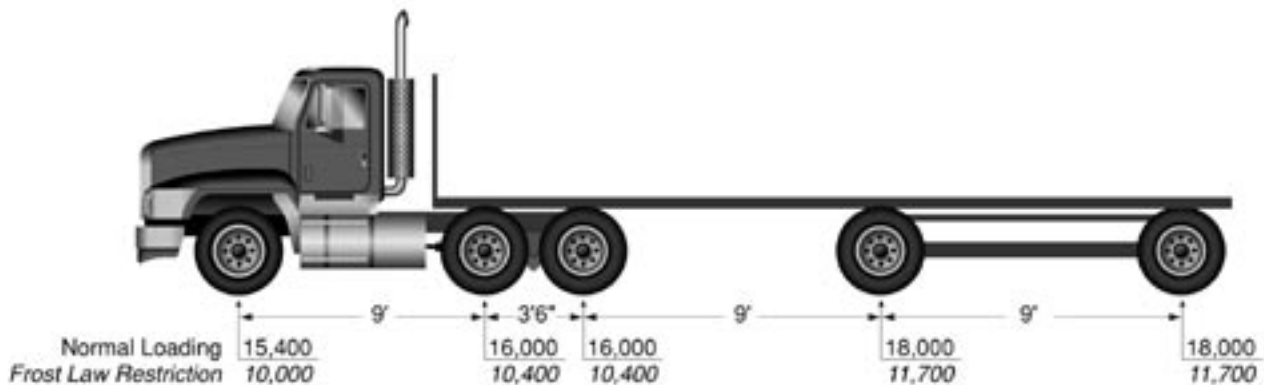
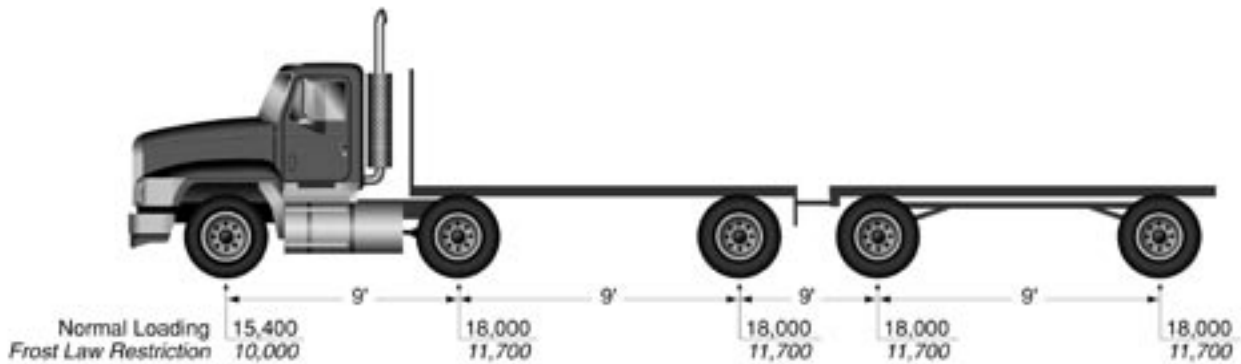
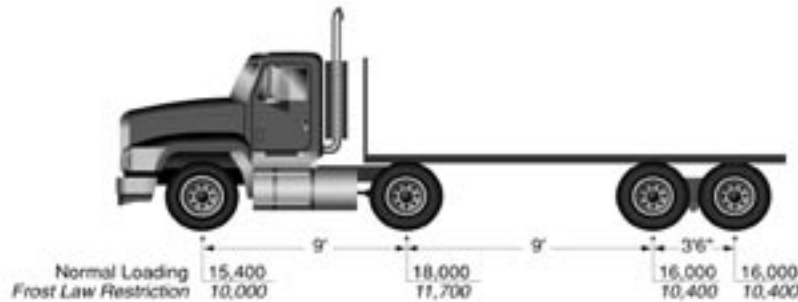
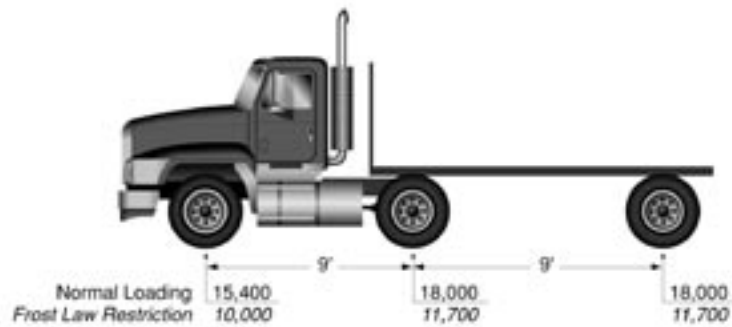

# Michigan Weight and Axle Load Limits

Examples of normal load maximums; frost law restrictions shown are at the 35 percent reduction.

